

END COVER COLOR : BLACK

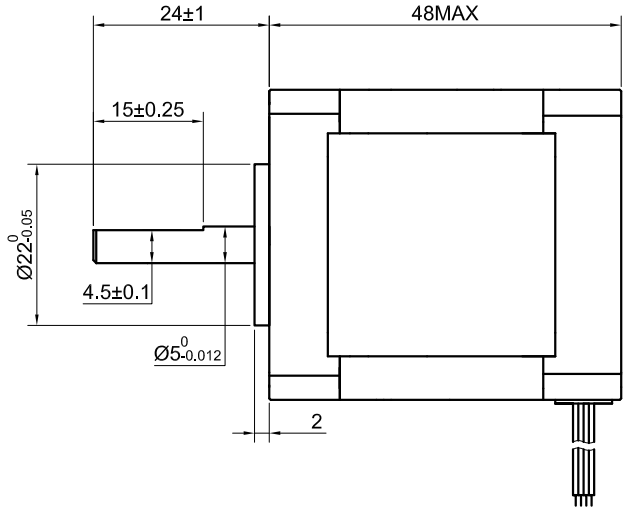
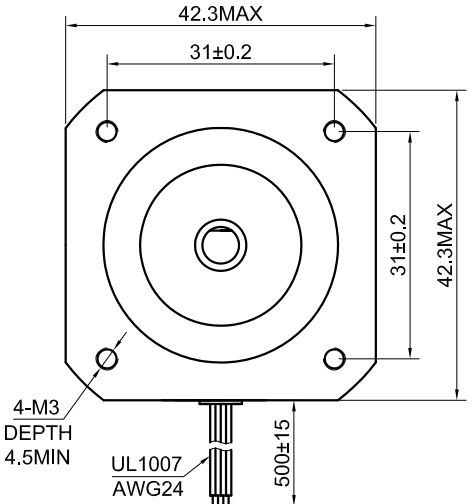

CONNECTION	BIPOLAR
SPECIFICATION	
AMPS/PHASE	0.85
RESISTANCE/PHASE(Ohms)@25°C	6.20±10%
INDUCTANCE/PHASE(mH)@1KHz	11.00±20%
HOLDING TORQUE(Nm)[lb-in]	0.44[3.89]
STEP ANGLE(°)	1.80
STEP ACCURACY(NON-ACCUM)	±5.00%
ROTOR INERTIA(g-cm ²)	62.00
WEIGHT(Kg)[lb]	0.35[0.77]
TEMPERATURE RISE:MAX.80°C (MOTOR STANDSTILL;FOR 2PHASE ENERGIZED)	
AMBIENT TEMPERATURE -10°C~50°C[14°F~122°F]	
INSULATION RESISTANCE 100 Mohm (UNDER NORMAL TEMPERATURE AND HUMIDITY)	
INSULATION CLASS B 130°C[266°F]	
DIELECTRIC STRENGTH 500VAC FOR 1MIN.(BETWEEN THE MOTOR COILS AND THE MOTOR CASE)	
AMBIENT HUMIDITY MAX.85%(NO CONDENSATION)	

TYPE OF CONNECTION (EXTERN)		MOTOR	
PIN NO	BIPOLAR	LEADS	WINDING
1	A+ —	BLK	A+
2	A- —	GRN	A-
3	B+ —	RED	B+
4	B- —	BLU	B-

FULL STEP 2 PHASE-Ex ,
WHEN FACING MOUNTING END (X)

STEP	A+	B+	A-	B-		CCW
1	+	+	-	-	↓	↑
2	-	+	+	-		
3	-	-	+	+	↑	↓
4	+	-	-	+		

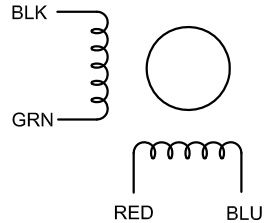

APVD		3.8.2023
CHKD		
1:1	DRN	
SCALE	SIGNATURE	DATE

STEPPER MOTOR

17HS19-0854S